



THE EFFECT OF LOADS, STRUCTURAL STIFFNESS AND SOIL VARIABILITY ON THE RELIABILITY AND PERFORMANCE OF PILE FOUNDATION

Gennaro Esposito, Gordon A. Fenton & Farzaneh Naghibi

Department of Engineering Mathematics and Internetworking, Dalhousie University, Halifax, NS B3J 2X4, Canada

ABSTRACT

In the settlement calculation, piles and piles groups are considered as isolated structural elements, neglecting their connection with other structural elements and the effect of the structural stiffness. This paper presents the results of a reliability analysis that considers the piles as part of a reinforced-concrete frame portal. The results are expressed in terms of the probability that differential settlements between piles supporting adjacent columns exceed the limiting values given in the National Building Code of Canada. The results indicate that the calculated reliability targets are much larger than those required by the codes. This confirms that the design practice is very robust to handle poor design practice and judgement. The results also stimulate a discussion on what a reasonable reliability target for geotechnical foundation systems should be, in order to ensure a balance between safety as well as design economy. Also, the current design methodology seems to be very punitive for good geotechnical engineering practice, triggering the question whether good practice should get rewarded by allowing more economical design.

RÉSUMÉ

Dans le calcul du tassement, les pieux et les groupes de pieux sont considérés comme des éléments de structure isolés, en négligeant leur connexion avec d'autres éléments de structure et l'effet de la rigidité structurelle. Cet article présente les résultats d'une analyse de fiabilité qui considère les pieux comme faisant partie d'un portail à ossature en béton armé. Les résultats sont exprimés en termes de probabilité que les tassements différentiels entre les pieux supportant des colonnes adjacentes dépassent les valeurs limites données dans le Code national du bâtiment du Canada. Les résultats indiquent que les objectifs de fiabilité calculés sont beaucoup plus grands que ceux requis par les codes. Cela confirme que la pratique de conception est très robuste pour gérer les mauvaises pratiques de conception et de jugement. Les résultats stimulent également une discussion sur ce que devrait être un objectif de fiabilité raisonnable pour les systèmes de fondation géotechniques, afin d'assurer un équilibre entre la sécurité et l'économie de la conception. De plus, la méthodologie de conception actuelle semble être très punitive pour les bonnes pratiques d'ingénierie géotechnique, ce qui soulève la question de savoir si les bonnes pratiques devraient être récompensées en permettant une conception plus économique.

1. INTRODUCTION

Pile foundations are designed for two Limit State conditions, the Ultimate Limit State (ULS) and Serviceability Limit State (SLS) conditions. Limit States are defined as conditions under which the engineered system no longer performs its intended function (CGS, 2021). ULS is primarily concerned with collapse mechanisms of the structure and, hence, safety. SLS instead represents conditions or mechanisms that restrict or constrain the intended use, function or occupancy of the structure under expected service or working loads. For both ULS and SLS conditions, piles are usually designed as isolated elements, ignoring their connection with the structures they support. Also, the soil variability is often averaged by considering a conservative subsurface model. For the SLS and ULS

design checks, it is often assumed that the differential settlement between two adjacent piles, δz is half of the largest single pile settlement. This is an attempt to make the settlements estimate more realistic by including the effects of soil variability and of the structural stiffness in the settlement estimate.

The effect of the structural stiffness on the intensity of the differential settlements has been investigated by a number of authors. Meyeroff (1953) was among the firsts to recognize that interaction between soil and structure can be quite significant, particularly for the cases of highly compressible soils. The foundation differential settlements influence the load transmitted from one column to another, and hence the redistribution of forces in the superstructure members. Later, Chamecki (1956) indicated that the magnitude of the load redistribution is dependent on the

stiffness of the elements of the superstructure as well as the magnitude of the differential settlement. Lee and Harrison (1970) and Lee and Brown (1972) analyzed how foundation settlements may introduce new conditions of load distribution in the structure, cause distress and cracking of its elements, particularly those in the lower stories, generate appreciable change in footing reactions, and may even lead to stress reversal. In their classic paper on the subject, Burland and Wroth (1974) quantified the critical value of tensile strain caused by differential settlements and associated to the onset of visible cracking for masonry and reinforced concrete buildings.

The authors of this paper are not aware of any investigation into the combined effect of soil variability and structural rigidity, perhaps due to the complexity of rigorous modelling of soil-foundation-structure interactions (SFSI). Also, the beneficial effect of soil data obtained from in-situ and laboratory investigation in reducing the soil characterization uncertainty, and consequently in the differential settlement prediction, seems overlooked. This paper aims at filling the gap and investigates the SFSI effect on pile foundation differential settlements, δz , in a fully probabilistic manner. A two-dimensional reinforced concrete frame portal on pile foundations is used to estimate the distribution of differential settlements with prior knowledge of the average soil conditions and with site-specific soil information. The distribution is used to estimate reliability levels which are finally compared to the target levels of the National Building Code of Canada (NBC – NRC 2015) with the final objective of assessing the reliability levels achieved by current practice when considering SFSI.

2. PILE FOUNDATION PERFORMANCE

For ULS conditions (NRC, 2015), typical pile design requires that the characteristic value of the ultimate geotechnical resistance (R_u) multiplied by a resistance factor (ϕ), which thus becomes the factored resistance (R_d), must be greater than or equal to the summation of the characteristic values of the axial load effects ($L_{k,i}$) acting on the pile multiplied by the corresponding load factors (α_i), which is the factored load (L_d):

$$R_d = \phi R_u \geq \sum \alpha_i L_{k,i} = L_d \quad [1]$$

For SLS conditions instead, a pile is designed to experience small settlements under the working load effect, which is the sum of the unfactored axial load effects (L_w). In reality, the ULS performance of pile foundations can also be linked to the settlements.

Figure 1 shows the load-settlement curve of a typical driven steel pipe pile. The ultimate settlement z_{ult} and the corresponding ultimate pile axial capacity L_{ult} are associated to the ULS of the piles and are typically determined using empirical or semi-empirical methods. In this study, the ultimate capacity is assumed to be the axial load L_{ult} at the settlement z_{ult} (Figure 1) corresponding to ten percent of the pile diameter.

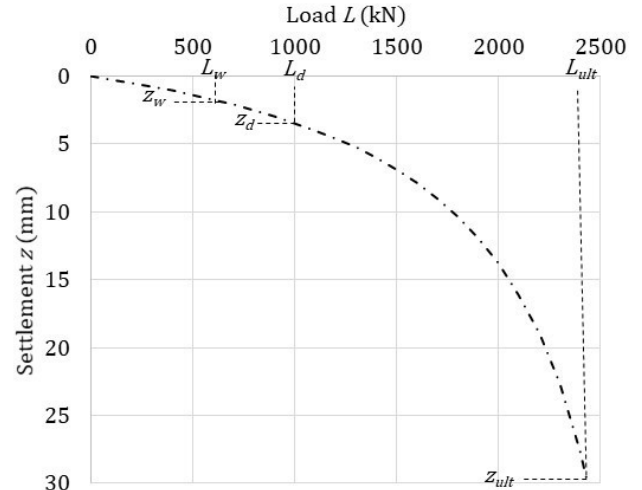

Figure 1. Load-settlement curves of a typical driven steel pipe pile

To satisfy the SLS conditions, the pile is designed to experience “small” settlements corresponding to relatively elastic conditions under the unfactored working load L_w , where “small” typically means equal to or less than a serviceability or design value z_w . Figure 1 also shows z_d , the design settlement corresponding to the factored load effect L_d ; z_d is implicitly associated to initiation of the ULS conditions. NBC (NRC 2015) defines the maximum SLS allowable deformation in terms of deflection/span ratio between two adjacent elements of the structure. The deflection/span ratio is equal to the differential settlement δz between two adjacent piles divided by the distance between them. Since δz is often taken as half of the single pile settlement, then half z_w divided by the distance between adjacent piles must not exceed the limits given in NBC (NRC 2015). It is important to note that z_d and z_{ult} are not identical and that z_d is usually much smaller than z_{ult} , which implies that a well-designed pile should experience settlements much smaller than the ultimate settlements. Also, NBC (NRC 2015) does not provide limiting deformations and settlements for the ULS conditions. In this study we calculate δz explicitly from the soil-foundation-structure model.

3. SOIL-FOUNDATION-STRUCTURE MODEL

3.1 General

To investigate the combined effect of soil, foundation, structure and loads, an integrated model is developed. The soil-foundation-structure interaction model consists of the following components:

- A random-field soil model to generate realizations of the soil properties at each pile location.
- A pile model to derive the load-deflection behaviour under the superstructure-imposed loads; and

- An elastic frame model to derive the superstructure internal forces and deflections caused by external loads;

The components are able to generate multiple realizations of loads and deformations, thus allowing a full probabilistic analysis of the system using Monte-Carlo simulation. Each component is briefly described below.

3.2 Random-Field Soil Model

The variability of the soil properties is modelled through multiple conditional simulations of a moderate-sized grid (up to 1,000 points) Gaussian random field based on the random point process. Details of the methodology are in Naghibi and Fenton (2016). In this study, we add to the model the possibility of conditioning the random field with measured data, for instance if a borehole were taken (Fenton and Griffiths, 2003, Fenton and Griffiths, 2008). The methodology is based on the Cholesky (LL') triangular decomposition of the covariance matrix. Let C be the covariance matrix associated with data locations (x_1, x_2, \dots, x_n) . Matrix C is symmetric and positive-definite and hence can be decomposed into the product of a lower triangular matrix and its transpose, $C = LL'$. Now, assuming a zero-mean of the modelled property, we can consider the random vector $Y = LW$, where W is a vector of independent $N(0,1)$ distributed random numbers. The expected value of the $n \times n$ matrix YY' is given by

$$E(YY') = E(LWW'U) = LE(WW')U \quad [2]$$

Because W is a vector of independent $N(0,1)$ random numbers, $E(WW') = I$, where I is the identity matrix and

$$E(YY') = LIL' = LL' = C \quad [3]$$

So the vector Y is an unconditional autocorrelated simulation of the random function at data locations with covariance matrix C . To generate a conditional simulation of a data grid, consider now the covariance matrix of the measured data locations (known) and the unknown points to be generated, and partition the matrix as follows

$$C = \begin{bmatrix} C_{11} & C_{12} \\ C_{21} & C_{22} \end{bmatrix} \quad [4]$$

where C_{11} is the covariance between known points (C), C_{21} is the covariance between known points and unknown points (to be simulated), and C_{22} is the covariance between unknown points. If a known point and an unknown point happen to coincide, the points are considered to be a known point and grouped accordingly, i.e., no duplication of data should occur at any point. Now matrix C can be decomposed as follows

$$C = \begin{bmatrix} C_{11} & C_{12} \\ C_{21} & C_{22} \end{bmatrix} = LL' = \begin{bmatrix} L_{11} & 0 \\ L_{21} & L_{22} \end{bmatrix} \begin{bmatrix} U_{11} & U_{12} \\ 0 & U_{22} \end{bmatrix} \quad [5]$$

Let $W' = (W'_1, W'_2)$ be a vector of independent $N(0,1)$ distributed random numbers. Then, the vector $Y' = (Y'_1, Y'_2)$ given by

$$\begin{bmatrix} Y_1 \\ Y_2 \end{bmatrix} = \begin{bmatrix} L_{11} & 0 \\ L_{21} & L_{22} \end{bmatrix} \begin{bmatrix} W_1 \\ W_2 \end{bmatrix} \quad [6]$$

is an unconditional simulation of the random function at the unknown and known points with covariance matrix C . Since $L_{11}W_1 = Y_1$ and $L_{21}W_1 + L_{22}W_2 = Y_2$, to condition the simulation, W_1 must be replaced by V_1 , where V_1 is the solution to the equation $L_{11}V_1 = z_1$ and z_1 is a vector of values at the known points. Note that all data are assumed to have been transformed so that $Z(x)$ is a $N(0,1)$ distributed random function. Note also that $E(z_1z'_1) = C_{11}$. Therefore

$$V_1 = L_{11}^{-1}z_1 \quad [7a]$$

and

$$\begin{bmatrix} L_{11} & 0 \\ L_{21} & L_{22} \end{bmatrix} \begin{bmatrix} L_{11}^{-1}z_1 \\ W_2 \end{bmatrix} = \begin{bmatrix} z_1 \\ L_{21}L_{11}^{-1}z_1 + L_{22}W_2 \end{bmatrix} \quad [7b]$$

produces a conditional simulation of the random function. Multiple simulations may be produced simply by regenerating the term $L_{22}W_2$ using different random numbers. Note that W_1 is not needed.

3.3 Piles Model

Given the column load and a pile diameter, this component "designs" piles to be able to resist the factored load and calculates the pile settlements. The pile design is based on the methodology in the Canadian Foundation Engineering Manual (CFEM - CGS, 2006), where the geotechnical resistance estimated from the random field model is factored and compared to the factored reaction loads calculated with the structural module. The pile settlements are calculated using load transfer ratios proposed by Reese and O'Neal (1988). The load transfer ratios are standardized load-settlement curves that become site-specific using the local geotechnical resistance. Figure 2 and 3 show the load transfer ratios used in this study. The model also calculates horizontal deflection and rotations of the pile top using the methodology in Poulos and Davis (1980). Pile settlements are calculated for each pile supporting each column of the superstructure. More details on the calculation of the pile geotechnical capacity and the load-settlement curves can be found in Esposito et al. (2020).

3.4 Superstructure Model

The structural response is calculated using conventional matrix analysis techniques (McGuire et al., 2000). The model is able to analyze structures (2D and 3D, trusses and frames) through the stiffness method and allows modelling of end release of members in frame elements and support displacements.

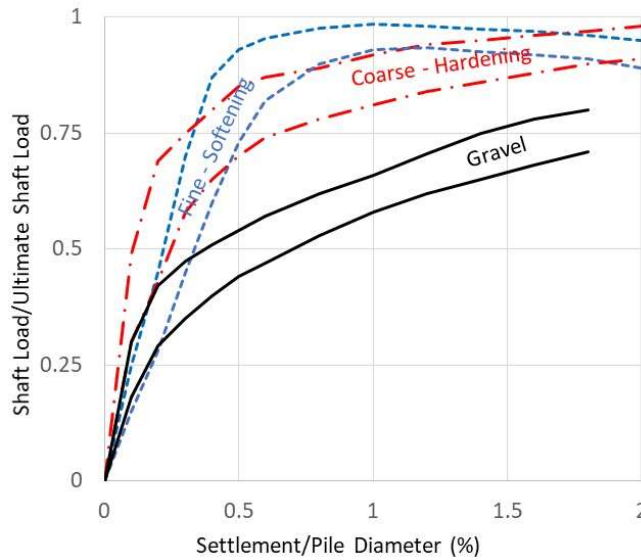

Figure 2 – Load transfer model for pile shaft

In this study, it is assumed that each column is supported by a single pile, however the methodology presented herein can be applied to columns supported by pile groups or shallow foundations by simply imposing the settlements of shallow foundations or pile groups to the supported columns.

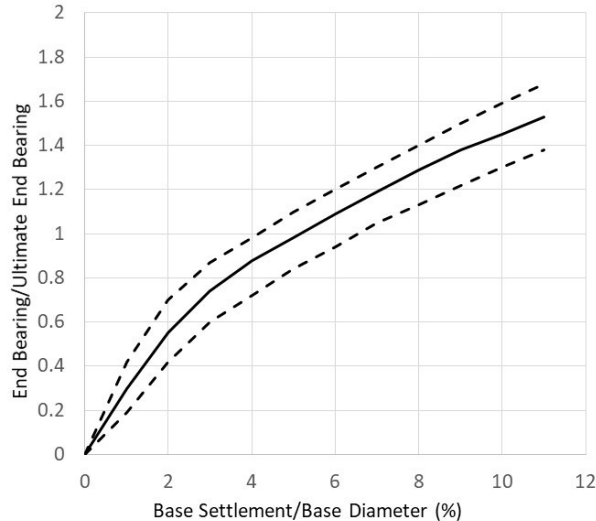

Figure 3 – Load transfer model for pile toe

4. MODEL CHARACTERISTICS

The two-dimensional reinforced concrete frame portal considered in this study is shown in Figure 4, along with its dimensions and the structural loads. Figure 4 also shows the unfactored columns loads applied to the piles, calculated considering fixed supports.

The columns have a cross section 0.16 m^2 , the beam has a cross-section equal to 0.15 m^2 , and all frame elements have an elastic modulus equal to $25 \times 10^6 \text{ kPa}$. Each column is supported by a single driven steel pipe pile having a diameter of 0.3 m .

The subsurface conditions consist of silt (Figure 5) and the pile geotechnical bearing capacity is calculated considering drained conditions and the beta method (CGS, 2006). The mean β_{soil} coefficients and the N_t factors used to calculate the geotechnical capacity are the central values of the ranges given in the Canadian Foundation Engineering Manual (CGS, 2006) and are summarized in Table 1. Two cases are considered to assess the reliability of the settlements. In the first, the mean values of the geotechnical resistance in Table 1 are considered to be the “known mean values” of the random field. In the second, the values of the geotechnical resistance in Table 1 are considered to be “measured values” at the location of pile 1, for instance through the execution of a Cone Penetration Testing (CPT) sounding. To generate the random field, it is assumed that correlation is anisotropic and therefore two correlation lengths are used, as specified in Figure 5.

Table 1 shows the statistics of the variable that are considered random in the probabilistic calculation.

Table 1 – Summary of the variables used for the analysis, statistics of the loads from Bartlett et al., (2003)

Quantity	Mean	COV	Bias	Distribution
Live load	150 kN	0.1	1.05	Normal
Dead load	20 kN/m	0.206	1.0	Normal
Specific weight	19 kN/m^3	0.2	1.0	Random Field Generation
Shaft resistance factor - β_{soil}	0.25	0.3	1.0	Random Field Generation
Bearing capacity factor - N_t	20	0.5	1.0	Random Field Generation

5. DIFFERENTIAL SETTLEMENTS LIMITS

NBC (NRC 2015) provides deformation limits for lateral distortion of adjacent constructive elements in terms of horizontal drift, expressed as the ratios of the maximum deflection and the span between adjacent structural elements, also referred to as drift ratios. Vertical drift is instead defined as the difference in vertical displacement of a column relative to an adjacent column divided by the spacing between them. The effect of vertical drift, on say

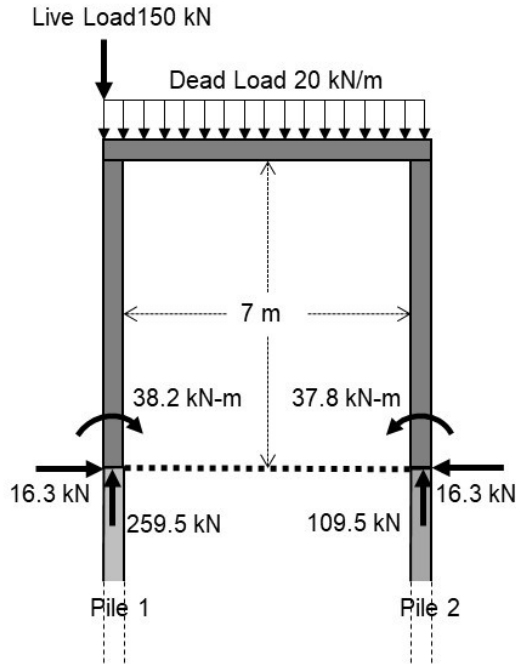

Figure 4 – Two-dimensional reinforced concrete frame portal considered for this study

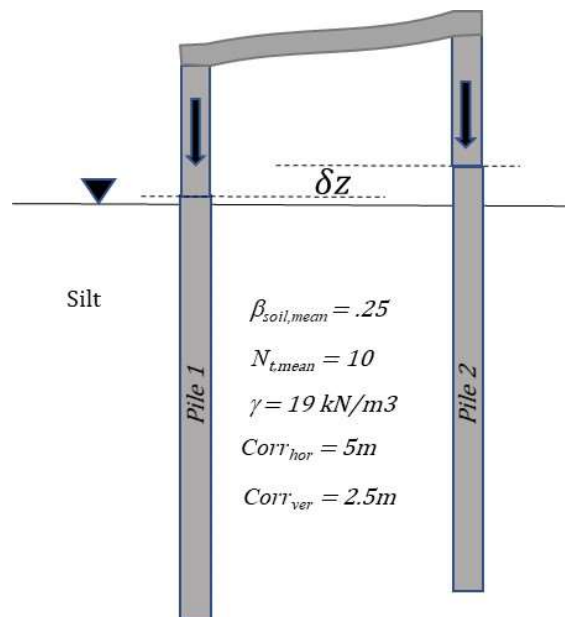

Figure 5. The soil conditions and the reinforced-concrete portal frame considered in this study

beam moments of a frame, is essentially the same as horizontal drift (Anderson et al., 2007). Thus, the horizontal drift limits given by NBC (NRC 2015) are considered applicable to vertical drifts in this paper. In section 9.4.3.1 and in Table D1 of the commentary, NBC (NRC 2015) provides drift limits for SLS conditions. For concrete structures, the limits are 0.4% (1:240) if attached components are unlikely to be damaged by the deflection and 0.2% (1:480) if instead the attached components are likely to be damaged.

NBC (NRC 2015) is silent on the deformation limits associated to ULS conditions. For structures subject to seismic loads having return period of 2,475 years, Anderson et al. (2007) defined maximum vertical drifts derived from the horizontal drifts given in section 4.1.8.13 of NBC (NRC 2015). The proposed vertical drift limits were 0.8% for post-disaster importance, 1.6% for high importance, and 2% for normal importance. In this study, it is assumed that the above vertical drifts are also applicable to other ULS load combinations. Thus, considering the span of the portal and the drift limits for normal importance, the following settlements limits are considered:

- For SLS, 0.4% of 7 m is equal to 0.028 m, or 28 mm.
- For ULS, 2% of 7 m is equal to 0.14 m, or 140 mm.

The target reliability level for the ULS case over a reference period of 50 years, $\beta_{50,ULS}$, is equal to 3.0 (Bartlett et al., 2003). The target reliability level for SLS conditions are not specified in NBC (NRC 2015). Following the logic of CHBDC (CSA 2015; Fenton et al. 2016), the target reliability index for the SLS case must be lower than $\beta_{50,ULS} = 3$, with a specific value depending on the maximum tolerable settlement needed to achieve or exceed the SLS. Following the provisions of the Eurocodes (CEN, 2002), we assume that the target reliability level $\beta_{50,SLS}$ for SLS conditions is equal to 1.8.

6. CALCULATION METHODOLOGY

The model described in the previous section is used to calculate the differential settlements δz between adjacent piles as follow.

Pile design using deterministic factored values:

- 1a. The factored column loads applied to the piles are calculated considering the factored structural load mean values in Table 1, fixed supports, and load combination 2 of NBC (NRC 2015). The structural loads mean values are multiplied by their respective load factors. We use load combination case 2 from NBC (NRC, 2015) where α_{Dead} is 1.2 and α_{Live} is 1.5.
- 2a. The factored column loads applied to the piles from step 1a and the factored geotechnical resistance from the mean values of Table 1 are used to calculate the “design pile lengths” according to the procedure given in CFEM (CGS, 2006). The design geotechnical resistance is multiplied by the geotechnical resistance factor ϕ that we take equal to 0.4
- 3a. The design pile lengths will be used for the probabilistic calculation of δz .

Probabilistic calculation of δz :

- 1b. Soil properties are generated with the random field soil model.
- 2b. The random structural loads are simulated from their distributions.

- 3b. The unfactored column loads applied to the piles are calculated considering the unfactored random structural loads from step 2b and fixed supports.
- 4b. With the design pile lengths from 3a and the unfactored column loads applied to the piles from 3b, the piles settlements are calculated considering one realization of the geotechnical resistance from step 1b; for brevity, we call these settlements “rigid support settlements”.
- 5b. The rigid support settlements from step 4b are imposed on the frame and new unfactored column loads applied to the piles are calculated.
- 6b. With the new unfactored column loads applied to the piles from step 5b, new pile settlements are calculated; for brevity, we call these settlements “flexible support settlements”.
- 7b. If the difference between the settlements from step 4b and the settlement from step 6b are smaller than an assigned tolerance (assumed here to be 0.5 mm), the calculation is stopped, the settlements are taken as those from step 6b, and δz is derived; otherwise the calculation goes back to step 5b and the settlements from step 6b are used for a new structural calculation of the unfactored column loads applied to the piles.
- 8b. Steps 5b to 7b are repeated for each realization of the soil and the loads.

The number of realizations necessary to obtain sufficient accuracy of the inferred statistical moments is based on the stability of the sample mean and variance of the differential settlement δz expressed through properties of statistical inference given in Ballie and Guadagnini (2004).

7. RESULTS

The results of the analysis are summarized in Figure 6. The blue line represents the cumulative distribution of the differential settlements obtained with the random field, whereas the red line represents the cumulative distribution of the differential settlements obtained with the random field conditioned with a CPT at the location of pile 1. The vertical black dashed lines represent the differential settlements of the deterministic rigid supports and flexible supports. Figure 6 also shows the SLS differential settlement limit for this particular frame portal and the NBC and the Eurocode (NRC, 2015, CEN, 2002) reliability targets. Note that due to the logarithmic horizontal axis, negative results are not shown in Figure 6. Negative differential settlements occur when pile 2 settles more than pile 1, which is very rare and not of significant magnitude.

For this particular portal, due to the redistribution of the frame’s internal forces and consequent changes in reactions, the deterministic flexible support differential settlements are about 10% of the deterministic rigid support differential settlements. The large amount of reduction experienced by the frame in this study (90%) should not be extrapolated to all structural configurations. SFSI depends on the combined effect of structure geometry, stiffness, and material properties as well as the differential settlement amount. For flexible and slender

structures, rigid support and flexible support differential settlements are much more similar. However, the rigid support differential settlements are an upper limit on the range of differential settlement values to be expected for different structural configurations.

The rigid support differential settlements are about one order of magnitude smaller than the SLS limit for this frame portal. The effect of including the variability of soil and loads is to increase the differential settlements with respect to the deterministic flexible support settlements. It is interesting to note that in this particular study, having known soil properties at the location of the pile subject to the larger axial load does not seem to help in decreasing the differential settlement. The reason is that at the pile 1 location the geotechnical capacity is “exact” and the resulting pile design precisely captures the available capacity. This assumption of precision is instead false at the pile 2 location, with the result that there will be realizations of the random field where pile 2 is too short and settlements and differential settlements are larger. Therefore, it seems more useful to have a robust knowledge of the subsurface mean properties and variability than having one data point and assuming its validity for the whole field. Finally, for this particular frame portal, irrespective of the support conditions, the differential settlements are four orders of magnitudes smaller than the NBC (NRC, 2015) ULS limit, indicating that if a pile is designed according to the codes and CFEM (CGS, 2006), its reliability is much larger than the code target.

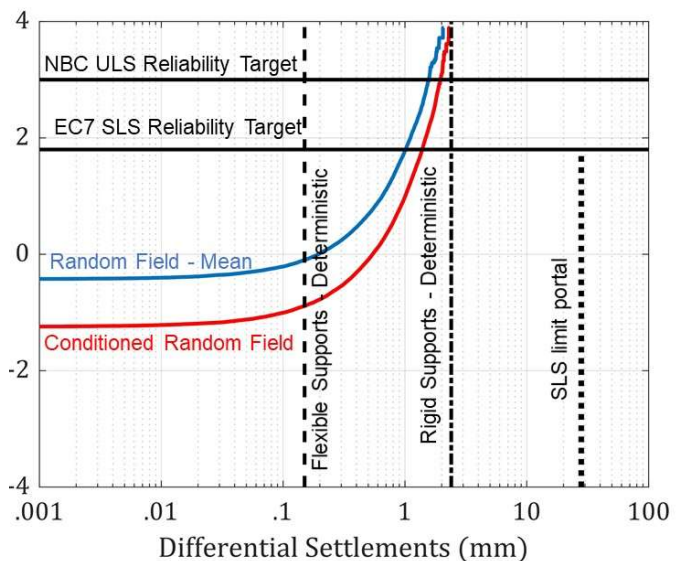

Figure 6 – Results of the modelling

8. CONCLUSIONS

In this study, we investigated the combined effects of structural rigidity and of soil and structural load variability on the differential settlements of adjacent columns supported by single piles. We conducted the geotechnical design process of pile foundations using the approach in CFEM (CGS, 2006), using the geotechnical resistance factors in NBC (NRC, 2015), and compared the distribution of the calculated differential settlements with the maximum

targets given for ULS in NBC (NRC, 2015) and SLS in Eurocode (CEN, 2002). The conclusions can be summarized as follow:

- When the subsurface conditions are well understood, the procedures in CFEM and the geotechnical resistance factors in NBC (NRC, 2015) produce a very conservative design, extremely unlikely to exceed the SLS and ULS differential settlement limits.
- In Canadian geotechnical practice, reports of bearing capacity failures (in the sense of excessive settlement or differential settlement) are extremely rare (Peck and Bryant, 1953). The results of this study based on a simple 2D frame portal show that the combined effects of design procedures and structural rigidity provide a very robust safeguard against poor understanding of the soil conditions in the pile design process.
- The SLS and ULS settlement limits specified in the codes were not achieved despite a large number of realizations used for the simulation, therefore the reliability levels for SLS and ULS must be much larger than what is assumed in the codes.
- Due to the consequence of geotechnical failures and to the difficulty of repairing a foundation, its accepted that the reliability targets for geotechnical foundation systems should be larger than those for the superstructures. It is however important to ask what a reasonable reliability target for geotechnical foundation systems should be, in order to ensure a balance between safety as well as design economy.
- Finally, the current design methodology seems to be very punitive for “good geotechnical” engineering practice. It is also reasonable to ask if good practice should get rewarded by allowing more economical design. The Canadian Highway Bridge Design Code (CHBDC – CSA, 2015) has now introduced the concept of level of understanding of the geotechnical conditions, explicitly recognizing that a good understanding of the geotechnical problem should be rewarded with higher geotechnical resistance factors for the ULS case. The results of this study indicate that there might be room to further increase the economy of design.

9. REFERENCES

- Ballie, F., Guadagnini, A., 2004. Convergence assessment of numerical Monte Carlo simulations in groundwater hydrology. WATER RESOURCES RESEARCH, VOL. 40, W04603, doi:10.1029/2003WR002876,
- Bartlett, F.M., Hong, H.P., Zhou, W., 2003. Load factor calibration for the proposed 2005 edition of the National Building Code of Canada: Companion-action load combinations. Can. J. Civ. Eng. 30: 440–448.
- Burland, J.B., Wroth, C.P., 1974. “Settlements of Buildings and associated Damage”, Proceedings of the British Geotechnical Society Conference on the Settlements of Structures, Cambridge, 1974.
- CEN (European Committee for Standardization), 2002. EN 1990:2002: Eurocode 0 – basis of structural design. CEN, Brussels, Belgium.
- Chamecki, S. "Structural Rigidity in Calculating Settlements." Journal of the Soil Mechanics and Foundation Division, ASCE, 82, SMI (1956), 1-19.
- Esposito, G., Fenton, G.A, Naghibi, F., 2020. Seismic Reliability of Axially Loaded Piles. Canadian Geotechnical Journal, <https://doi.org/10.1139/cgj-2019-0342>
- Fenton, G.A., and Griffiths, D.V., Risk Assessment in Geotechnical Engineering, John Wiley & Sons, New York, 2008.
- Fenton, G.A., and Griffiths, D. V. 2003. Bearing-capacity prediction of spatially random $c - \phi$ soils", Canadian Geotechnical Journal, 40(1): 54–65.
- Fenton GA, Griffiths DV. 2002. Probabilistic foundation settlement on spatially random soil. Journal of Geotechnical and Geoenvironmental Engineering 128(5): 381-390 Crossref, ISI, Google Scholar.
- Fenton, G.A, Naghibi, F., Dundas, D, Bathurst, R.J., Griffiths, D. V., 2015. Reliability-Based Geotechnical Design in the 2014 Canadian Highway Bridge Design Code. Can.n Geotech J, 10.1139/cgj-2015-0158.
- Lee, I.K. and Harrison, H.B. "Structure and Foundation Interaction Theory." Journal of the Structural Division, ASCE, 96, No. ST2 (1970), 177-197.
- Lee, I.K. and Brown, P.T. "Structure-Foundation Interaction Analysis." Journal of the Structural Division, ASCE, 98, No. ST11(1972), 2413-2431.
- Meyerhof, G.G. "Some Recent Foundation Research and its Application to Design." The Structural Engineer, 31 (1953), 151-167.
- Naghibi, F., Fenton, G.A, Griffiths, D.V., 2015. Probabilistic considerations for the design of deep foundations against excessive differential settlement. Canadian Geotechnical Journal, 2016, Vol. 53, No. 7 : pp. 1167-1175
- Naghibi, F., and Fenton, G.A. 2019. Calibration of Resistance Factors for Geotechnical Seismic Design. Canadian Geotechnical Journal, 2019, 56(8): 1134-1141
- Peck, R.B., Bryant, F.G., 1953. The Bearing-Capacity Failure Of The Transcona Elevator. Geotechnique, Volume 3 Issue 5, March 1953, pp. 201-208
- Poulos, H.G., Davis, E.H., 1980. Pile Foundation Analysis and Design. Series in geotechnical engineering. Wiley, New York, NY.
- Reese, L. C. and O'Neill, M., 1971. Criteria for Design of Axially Loaded Drilled Shafts, Center for Highway Research Report, University of Texas, August, 1971.